

# Replace the Pump Tube – BDF

---

Entire document: 6 pages

**THIS DOCUMENT CONTAINS GENERAL INSTRUCTION FOR SERVICING STENNER PRODUCTS. PLEASE BE SURE TO READ ALL SAFETY INFORMATION.**

 **NOTICE:** Indicates special instructions or general mandatory action.

 **NOTICE:** Read all safety hazards before installing or servicing the pump. The pump is designed for installation and service by properly trained personnel.

 **NOTICE:** Use all required personal protective equipment when working on or near a chemical metering pump.

 **NOTICE:** Install the pump so that it is in compliance with all national and local plumbing and electrical codes.

 **NOTICE:** Use the proper product to treat potable water systems, use only chemicals listed or approved for use.

 **NOTICE:** Install the pump to work in conjunction with pool, spa, well pump, or system controls.





## Safety Information – BDF

 **WARNING** Warns about hazards that **CAN** cause death, serious personal injury, or property damage if ignored.

 **ELECTRIC SHOCK HAZARD**

 **WARNING** **ELECTRIC SHOCK HAZARD:**  
Pump supplied with grounding power cord and attached plug. To reduce risk of electrical shock, connect only to a properly grounded, grounding type receptacle. Install only on a circuit protected by a ground-fault circuit interrupter (GFCI).

 **AVERTISSEMENT** **RISQUE DE CHOC ELECTRIQUE:**  
Cette pompe est équipée d'une fiche de mise à terre. Pour réduire le risque de choc électrique, s'assurer que la fiche est bien raccordée à une prise de courant avec une connexion de mise à terre. Installer seulement sur un circuit protéger par un interrupteur protéger par une mise à la terre.

 **DO NOT** alter the power cord or plug end.

 **DO NOT** use receptacle adapters.

 **DO NOT** use pump with a damaged or altered power cord or plug. Contact the factory or an authorized service facility for repair.

 **WARNING** **RISK OF CHEMICAL EXPOSURE:**  
Potential for chemical burns, fire, explosion, personal injury, or property damage. To reduce risk of exposure, the use of proper personal protective equipment is mandatory.

 **WARNING** **RISK OF FIRE HAZARD:**  
**DO NOT** install or operate on any flammable surface.

 **WARNING** **HAZARDOUS VOLTAGE:**  
**DISCONNECT** power cord before removing motor cover for service. **Electrical service by trained personnel only.**

 **WARNING** **EXPLOSION HAZARD:**  
This pump is not explosion proof. **DO NOT** install or operate in an explosive environment.

 Pump is equipped with a safety interlock switch. This switch ensures that all supply voltage is disconnected from the timer board in the event the cover is removed prior to unplugging the power cord. **DO NOT** tamper with or alter this switch in any way. Failure to follow this warning will void the warranty and can lead to personal injury or property damage.

 **Electrical service by trained personnel only.** Pump **IS NOT** user serviceable in regards to electrical components. Contact the factory or an authorized service facility for repair.

 **NOTICE:** Indicates special instructions or general mandatory action.

 **NOTICE:** This metering pump is portable and designed to be removable from the plumbing system without damage to the connections.

 **NOTICE:** This metering pump and its components have been tested for use with the following chemicals: Sodium Hypochlorite (10-15%), Muriatic Acid (20-22% Baume, 31.5% Hcl), and Soda Ash.

 **NOTE:** Cette a pompe de dosage et ses composants ont été testés pour utilisation avec les produits chimiques suivants; Hypochlorite de Sodium (solution de 10-15%); Acide Muriatique (20-22% Baume, 31.5% Hcl); Cendre de Soude.

 This is the safety alert symbol. When displayed in this manual or on the equipment, look for one of the following signal words alerting you to the potential for personal injury or property damage.

 Electrical installation should adhere to all national and local codes. Consult a licensed professional for assistance with proper electrical installation.





 **PUMP INTENDED FOR INDOOR USE.**

 Cette pompe est prévue pour utilisation à l'intérieur.



## Safety Information – Replace the Pump Tube



### **WARNING** RISK OF CHEMICAL EXPOSURE:

-  To reduce risk of exposure, check the pump tube regularly for leakage. At the first sign of leakage, replace the pump tube.
-  To reduce risk of exposure, the use of proper personal protective equipment is mandatory when working on or near chemical metering pumps.
-  To reduce risk of exposure, and also prior to service, shipping, or storage, pump generous amounts of water or a compatible buffer solution to remove chemical from pump.
-  Consult chemical manufacturer and MSDS sheet for additional information and precautions for the chemical in use.
-  Personnel should be skilled and trained in the proper safety and handling of the chemicals in use.





### **CAUTION** PINCH POINT HAZARD:

-  Use extreme caution when replacing pump tube. Be careful of your fingers and **DO NOT** place fingers near rollers.

### **WARNING** HAZARDOUS PRESSURE/CHEMICAL EXPOSURE:

-  Use caution and bleed off all resident system pressure prior to attempting service or installation.
-  Use caution when disconnecting discharge tubing from pump. Discharge may be under pressure. Tubing may contain chemical.

### **NOTICE: Indicates special instructions or general mandatory action.**

-  **NOTICE: DO NOT** apply grease, oil, or lubricants to the pump tube or housing.
-  **NOTICE:** Prior to pump tube replacement, inspect the entire pump head for cracks or damaged components. Ensure rollers turn freely.
-  **NOTICE:** Rinse off chemical residual and clean all chemical and debris from pump head components prior to tube replacement. Apply grease (AquaShield®) to main shaft and tube housing cover bushing during tube replacement.
-  **NOTICE: DO NOT** pull excessively on pump tube. Avoid kinks or damage during tube installation.
-  **NOTICE:** Inspect the suction/discharge tubing, injection point (into pipe), and injection check valve duckbill for blockages after any tube rupture. Clear or replace as required.

## Replace the Pump Tube – Preparation

1. Follow all safety precautions prior to tube replacement.
2. Prior to service, pump water or a compatible buffer solution through the pump and suction/discharge line to remove chemical and avoid contact.
3. Turn pump off.
4. Disconnect the suction and discharge connections from pump head.
5. Plug power cord into constantly energized, properly grounded receptacle for service.



## Replace the Pump Tube – BDF

### Remove Old Tube

1. Turn the metering pump off.
2. Remove and set aside cover and screws.
3. Press the PRIME button to jog the roller assembly until one of the three slots in the roller assembly lines up with the bottom tube fitting (suction side). **Illustration A**
4. Turn pump off.
5. Lift tube fitting out of housing slot and pull it toward center of roller assembly. **Illustration B**
6. Press the PRIME button to jog the roller assembly while guiding the tube, with tension, up and out of housing. **Illustration C**
7. Turn pump off. When the slot in the roller assembly aligns with the "OUT" (discharge) tube fitting, remove and discard pump tube.
8. Remove roller assembly and housing.
9. Use non-citrus all-purpose cleaner to clean chemical residue from pump head housing, roller, and cover.
10. Check housing for cracks. Replace if cracked.
11. Ensure rollers spin freely. **Illustration D**
12. Replace roller assembly if: seized, excessive side play from bore wear, or if rollers are visibly worn.
13. Reinstall clean tube housing.
14. Install roller assembly.

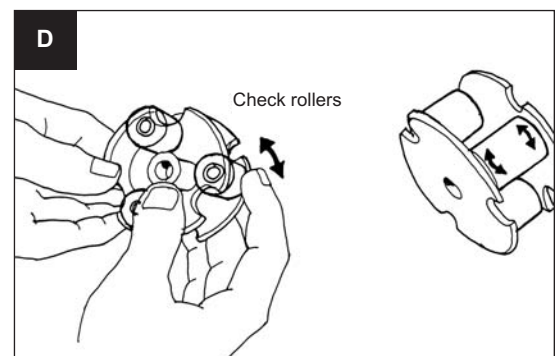
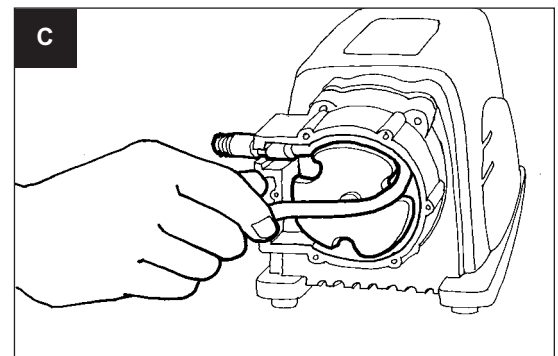
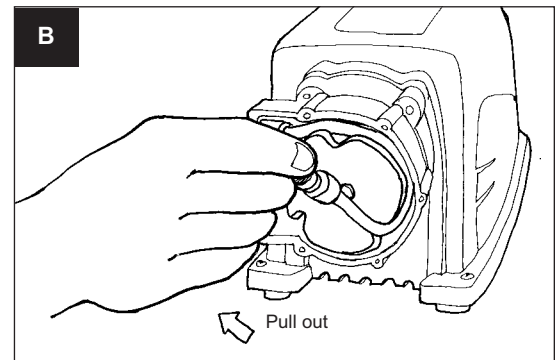
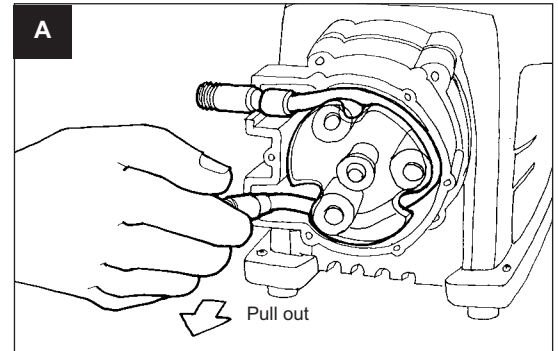

## Replace the Pump Tube – BDF

### Install New Tube



**IMPORTANT!**

Key for optimum performance:

**DO NOT lubricate pump tube or roller assembly.**

1. Press the PRIME button until one of the slots in the roller assembly aligns with the "IN" (suction) tube fitting slot in the housing. Press again to stop.
2. Place tube fitting into suction side slot of the housing and the roller assembly slot. **Illustration E**
3. Press the PRIME button to jog the roller assembly while guiding the tube to prevent it from getting pinched between the housing and roller assembly.
4. Guide tube, with slight tension (toward the center) to prevent pinching between housing and roller assembly. **Illustration F**
5. When the roller assembly slot reaches the housing slot that the fitting inserts into, depress the PRIME button to aid in stretching the tube assembly until it can be inserted into the housing.
6. Allow rollers to stretch tube into place while guiding tube into slot. **Illustration G**
7. Press the PRIME button to turn off.
8. Apply a small amount of grease (AquaShield®) to cover bushing **ONLY** and replace cover and two screws, leaving front screw in-between the fittings loose.



**NOTE**

Additional information:

**Cover Screws are self-tapping and must be backed in to locate original thread before securing. If a screw boss is stripped, use alternate bosses and position opposite from each other. NEVER secure the cover plate with more than 2 screws.**

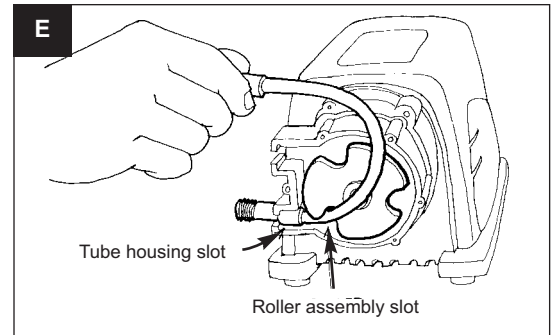

**IMPORTANT!**

Key for optimum performance:

**Avoid rotating wrist, which can result in a twisted tube that will not center. DO NOT force tube and be careful of your fingers.**

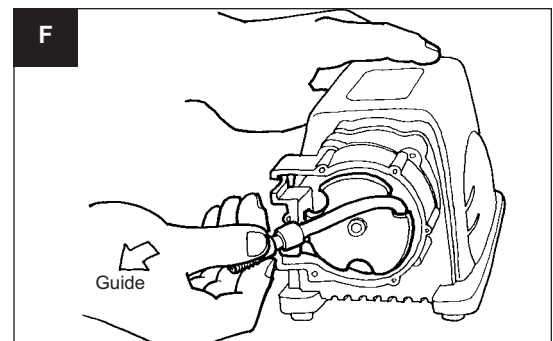

**NOTE**

Additional information:

**A used tube will have stretch approximately 3/4" and the new tube will appear to be stiff and short. Follow directions to allow rollers to stretch tube into place.**

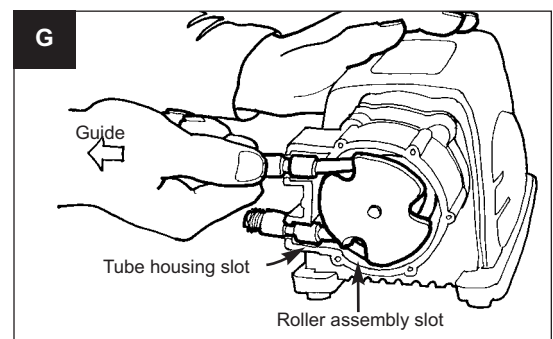

# Replace the Pump Tube – BDF

## Center New Tube

1. To center the tube on the rollers, press the PRIME button to continually rotate the rollers. **Illustration H**
2. Turn the tube fitting on the suction side not more than 1/8 of a turn in the direction tube must move.
3. **DO NOT** let go of fitting until tube rides approximately in center of rollers.
4. Press the PRIME button to turn "Off." Tighten cover screws. Cover is not on securely if there is a gap between screw boss and cover. **Illustration I**

