

# Replace the Pump Tube – Classic

---

Entire document: 7 pages

**THIS DOCUMENT CONTAINS GENERAL INSTRUCTION FOR SERVICING STENNER PRODUCTS. PLEASE BE SURE TO READ ALL SAFETY INFORMATION.**

**!** **NOTICE:** Indicates special instructions or general mandatory action.

**!** **NOTICE:** Read all safety hazards before installing or servicing the pump. The pump is designed for installation and service by properly trained personnel.

**!** **NOTICE:** Use all required personal protective equipment when working on or near a chemical metering pump.

**!** **NOTICE:** Install the pump so that it is in compliance with all national and local plumbing and electrical codes.

**!** **NOTICE:** Use the proper product to treat potable water systems, use only chemicals listed or approved for use.

**!** **NOTICE:** Install the pump to work in conjunction with pool, spa, well pump, or system controls.





# Safety Information – Classic

 **WARNING** Warns about hazards that **CAN** cause death, serious personal injury, or property damage if ignored.

 **ELECTRIC SHOCK HAZARD**

 **WARNING** **ELECTRIC SHOCK HAZARD:**  
Pump supplied with grounding power cord and attached plug. To reduce risk of electrical shock, connect only to a properly grounded, grounding type receptacle. Install only on a circuit protected by a ground-fault circuit interrupter (GFCI).

 **WARNING** **HAZARDOUS VOLTAGE:**  
**DISCONNECT** power cord before removing motor cover for service. **Electrical service by trained personnel only.**

 **AVERTISSEMENT** **RISQUE DE CHOC ELECTRIQUE:**  
Cette pompe est équipée d'une fiche de mise à terre. Pour réduire le risque de choc électrique, s'assurer que la fiche est bien raccordée à une prise de courant avec une connexion de mise à terre. Installer seulement sur un circuit protéger par un interrupteur protéger par une mise à la terre.

 **WARNING** **EXPLOSION HAZARD:**  
This pump is not explosion proof. **DO NOT** install or operate in an explosive environment.

 **DO NOT** alter the power cord or plug end.

 **WARNING** **RISK OF CHEMICAL EXPOSURE:**  
Potential for chemical burns, fire, explosion, personal injury, or property damage. To reduce risk of exposure, the use of proper personal protective equipment is mandatory.

 **DO NOT** use receptacle adapters.

 **WARNING** **RISK OF FIRE HAZARD:**  
**DO NOT** install or operate on any flammable surface.

 **DO NOT** use pump with a damaged or altered power cord or plug. Contact the factory or an authorized service facility for repair.

 **WARNING** **RISK OF CHEMICAL OVERDOSE:**  
To reduce risk, follow proper installation methods and recommendations. Check your local codes for additional guidelines.

 **CAUTION** Warns about hazards that **WILL** or **CAN** cause minor personal injury or property damage if ignored.

 **This is the safety alert symbol. When displayed in this manual or on the equipment, look for one of the following signal words alerting you to the potential or personal injury or property damage.**

 **CAUTION** **PLUMBING:**

Chemical feed pump installation must always adhere to your local plumbing codes and requirements. Be sure installation does not constitute a cross connection. Check local plumbing codes for guidelines.

 **PUMP SUITABLE FOR USE OUTDOORS** when installed with a Stenner Rain Roof Part No. MP90000.

 **NOTICE: Indicates special instructions or general mandatory action.**

 Electrical installation should adhere to all national and local codes. Consult a licensed professional for assistance with proper electrical installation.

 **NOTICE:** This metering pump is portable and designed to be removable from the plumbing system without damage to the connections.

 Removing power from pool/spa recirculation pump must also remove power from pump.

 **NOTICE:** This metering pump and its components have been tested for use with the following chemicals: Sodium Hypochlorite (10-15%), Muriatic Acid (20-22% Baume, 31.5% Hcl), and Soda Ash.

 The use of an auxiliary safety device (not supplied), such as a flow switch or sensor, is recommended to prevent feed pump operation in the event of a recirculation pump failure or if flow is not sensed.

 **NOTE:** Cette a pompe de dosage et ses composants ont été testés pour utilisation avec les produits chimiques suivants; Hypochlorite de Sodium (solution de 10-15%); Acide Muriatique (20-22% Baume, 31.5% Hcl); Cendre de Soude.

 Point of chemical injection should be beyond all pumps, filters, and heaters.

 Suitable for indoor and outdoor use.

 Convient pour usage intérieur et extérieur..



# Safety Information – Replace the Pump Tube

**⚠️ ⚠️ WARNING RISK OF CHEMICAL EXPOSURE:**

- ⚠️ To reduce risk of exposure, check the pump tube regularly for leakage. At the first sign of leakage, replace the pump tube.
- ⚠️ To reduce risk of exposure, the use of proper personal protective equipment is mandatory when working on or near chemical metering pumps.
- ⚠️ To reduce risk of exposure, and also prior to service, shipping, or storage, pump generous amounts of water or a compatible buffer solution to remove chemical from pump.
- ⚠️ Consult chemical manufacturer and MSDS sheet for additional information and precautions for the chemical in use.
- ⚠️ Personnel should be skilled and trained in the proper safety and handling of the chemicals in use.

**⚠️ ⚠️ CAUTION PINCH POINT HAZARD:**

- ⚠️ Use extreme caution when replacing pump tube. Be careful of your fingers and **DO NOT** place fingers near rollers.

**⚠️ ⚠️ WARNING HAZARDOUS PRESSURE/CHEMICAL EXPOSURE:**

- ⚠️ Use caution and bleed off all resident system pressure prior to attempting service or installation.
- ⚠️ Use caution when disconnecting discharge tubing from pump. Discharge may be under pressure. Tubing may contain chemical.

**❗ NOTICE: Indicates special instructions or general mandatory action.**

- ❗ **NOTICE: DO NOT** apply grease, oil, or lubricants to the pump tube or housing.
- ❗ **NOTICE:** Prior to pump tube replacement, inspect the entire pump head for cracks or damaged components. Ensure rollers turn freely.
- ❗ **NOTICE:** Rinse off chemical residual and clean all chemical and debris from pump head components prior to tube replacement. Apply grease (AquaShield®) to main shaft and tube housing cover bushing during tube replacement.
- ❗ **NOTICE: DO NOT** pull excessively on pump tube. Avoid kinks or damage during tube installation.
- ❗ **NOTICE:** Inspect the suction/discharge tubing, injection point (into pipe), and injection check valve duckbill for blockages after any tube rupture. Clear or replace as required.

# Replace the Pump Tube – Preparation

1. Follow all safety precautions prior to tube replacement.
2. Prior to service, pump water or a compatible buffer solution through the pump and suction/discharge line to remove chemical and avoid contact.
3. Turn pump off.
4. Disconnect the suction and discharge connections from pump head.
5. Plug power cord into constantly energized, properly grounded receptacle for service.



# Replace the Pump Tube – Classic

**BEST PRACTICE**

Factory recommended:

**Prior to tube removal, pump water through tube to remove chemical.**

## Remove the Old Pump Tube

1. Turn pump off.
2. Remove and set aside cover and screws.
3. Set feed rate dial on the low setting until finished.
4. Turn pump on and let it run until one of three roller assembly slots lines up with the tube fitting on the suction side.
5. Turn pump off.
6. Lift tube fitting out of housing slot and pull it toward center of roller assembly.
7. Turn pump on and allow roller assembly to jog while guiding tube, with tension, up and out of housing.
8. Turn pump off. Remove and discard pump tube.

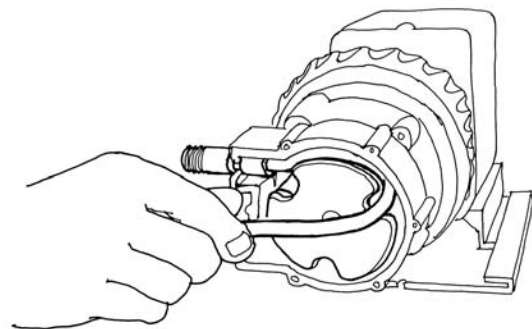
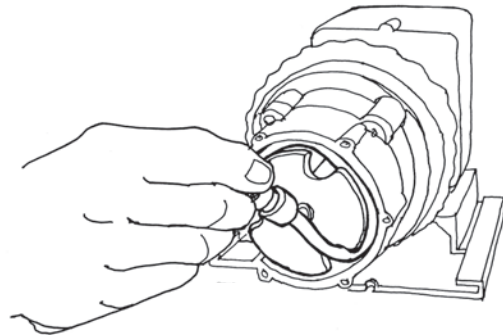
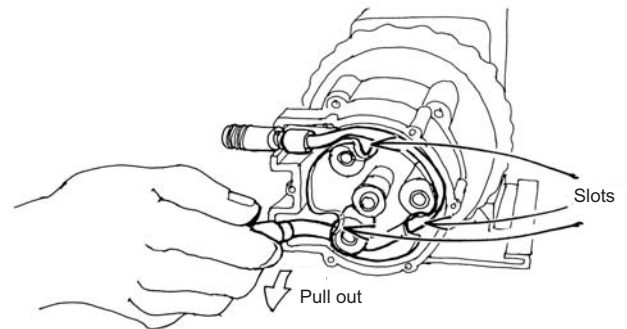
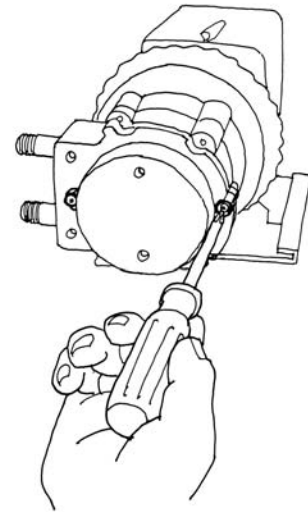

# Replace the Pump Tube – Classic

**IMPORTANT!**

Key for optimum performance:

**Identify the cause of tube failure prior to installing a new tube.**

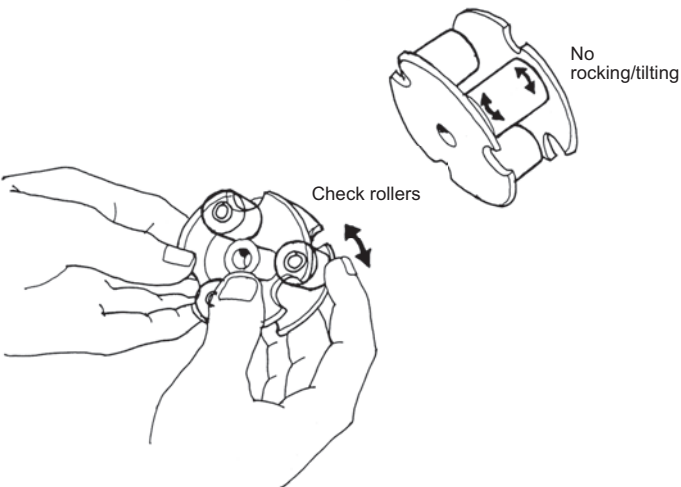
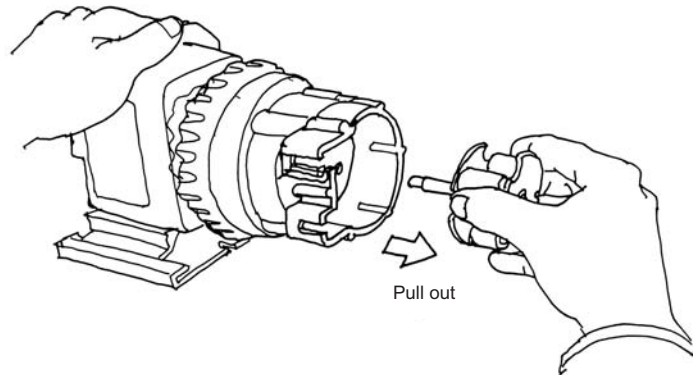

## After Removing Old Tube

1. Remove roller assembly, shaft, and housing.
2. Use non-citrus all-purpose cleaner to clean chemical residue from pump head housing, roller, and cover.
3. Check housing for cracks and replace if cracked.
4. Ensure rollers spin freely.
5. Replace roller assembly if: seized, excessive side play from bore wear, or if rollers are visibly worn.
6. Inspect the suction/discharge tubing, point of injection, and check valve duckbill for blockages. Clean and/or replace as required.
7. Reinstall clean housing.
8. Grease shaft tip and install.
9. Install roller assembly.



## Replace the Pump Tube – Classic

### Install New Pump Tube

1. Manually rotate the roller assembly counter clockwise to align one of three roller assembly slots with the suction side housing slot.
2. Place tube fitting into suction side slot of the housing and the roller assembly slot.
3. With pump setting on low, hold tube fitting and jog roller assembly by turning pump on.

**IMPORTANT!** Avoid rotating wrist, which can result in a twisted tube that will not center. **DO NOT** force tube and be careful of your fingers.

4. Guide tube, with slight tension (toward the center) to prevent pinching between housing and roller assembly.
5. When tube reaches the top housing slot, turn pump off.
6. Turn dial ring to setting 10, hold tube fitting firmly, and turn pump on.

**NOTE:** A used tube will have stretched approximately 3/4" and the new tube will appear to be stiff and short. Follow directions to allow rollers to stretch tube into place.

7. Allow rollers to stretch tube into place while guiding tube into slot.
8. Turn pump off.
9. Apply a small amount of grease (AquaShield®) to cover bushing **ONLY** and replace cover and two screws, leaving front screw in-between the fittings loose.

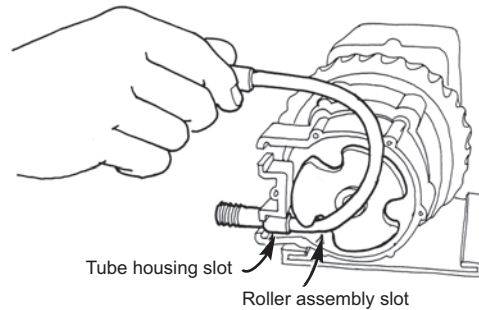

**IMPORTANT!**  
Key for optimum performance:  
**DO NOT** lubricate pump tube or roller assembly.

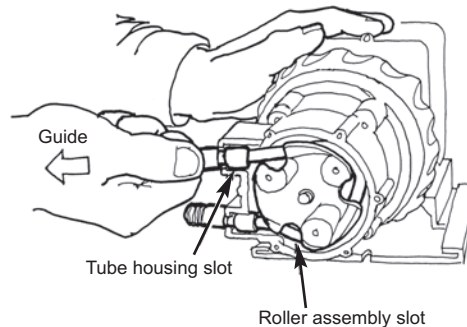
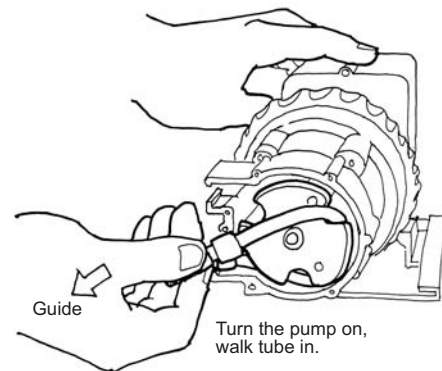

**BEST PRACTICE**  
Factory recommended:  
**Trim 1" off suction/discharge tubing before installing ferrules. Replace ferrules with every tube change.**

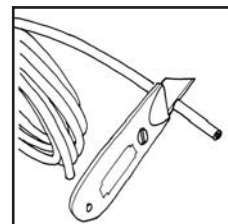

# Replace the Pump Tube – Classic

## Center the Pump Tube

1. To center pump tube on rollers, set feed rate dial to setting 10. Turn pump on.
2. Turn the tube fitting on the suction side not more than 1/8 of a turn in the direction tube must move.
3. **DO NOT** let go of fitting until the tube rides approximately in the center of the rollers.
4. Turn the pump off, let go of fitting, and tighten the cover screws\*. The cover is not on securely if there is a gap between the screw boss and the cover.

\*Screws are self-tapping and must be backed in to locate original threads before securing, to prevent stripping screw boss.



**NOTE**  
Additional information:  
**If pump head housing screws are stripped, use alternate bosses and position them opposite each other. Use only two at a time.**

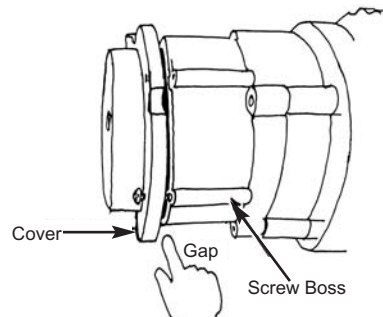
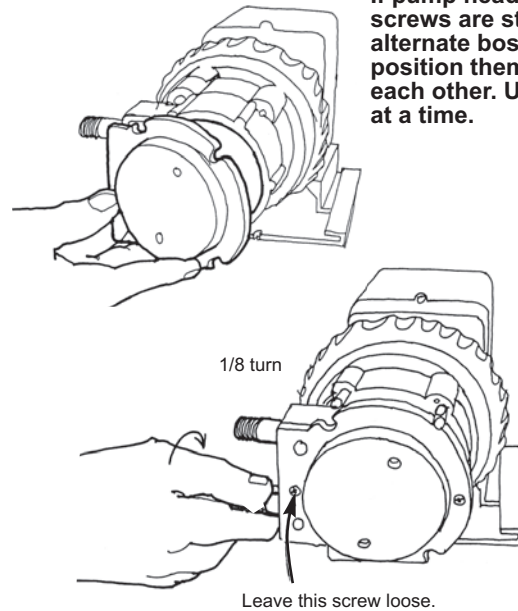

## Fixed Rate Pump Tube Change

To install a new tube in a fixed rate pump, utilize the on/off switch to jog the roller assembly in absence of the feed rate control.

